

The Circuits

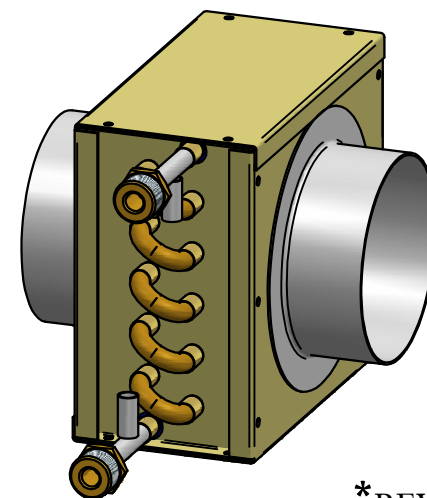
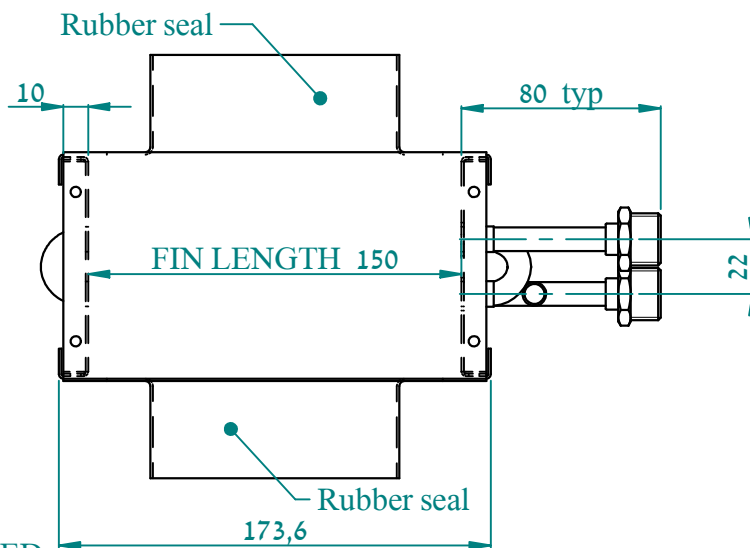

*REVISED

Holes should be sealed to avoid air leakage
 Fin: ALUMINIUM, 0.12 mm , CORRUGATED
 Tubes: COPPER, 0.012"
 End Plates: GALVANIZED, 1mm
 T/B Plates: GALVANIZED, 1mm

TOLERANCE UNLESS SPECIFIED

LINEAR DIMENSIONS	ANGULAR	FINS DENSITY
UP TO 400 mm - ±2	OVER 400 - ISO 2768-C	±4 %

NO.	DATE	BY
C	29/09/2015	David
B	14-03-2014	tomasz

ttc BOX_V_Ø100

Customer: TT Coils Denmark
 Model No. D-100

Description: 9/2x6x150/16-1 (0)		COR	
Cat. No. 809 - TJ216		scale	
date	by	proj	
design	26/03/2014	tomasz	
check		Dr/Nr TJ216	
app.		rev	